

Rigging for Bondage Rigger.

By Dunter
2018
V.3



Rigging for Bondage Rigger.

- Lexicon
 - Forces, Vector, Angles
 - Design , Estimation
 - Frame, Anchor
 - Ropes & Knots
 - Pulley systems
 - Hardware
 - Laws & certification & insurance
 - Less know danger
 - Q & A
-
-

Lexicon

- Abrasion : the process of scraping or wearing away. Creation of Heat.
 - Breaking point : the moment of greatest strain at which someone or something gives way.
 - Block & tackles : A block and tackle is a system of two or more pulleys with a rope or cable threaded between them.
 - Carabiner : a coupling link with a safety closure, used by rock climbers.
 - Choke & basket : way to attach load.
 - Chain : a connected flexible series of metal links used for fastening or securing objects and pulling or supporting loads.
 - DF : Design Factor, a factor of safety.
-
-

Lexicon

- Deflection +-
 - Design Factor, Factory feature for the WLL
 - Elasticity : is a measure of a variable's sensitivity to a change in another variable. Some ropes got 60% longer before breaking point.
 - Efficiency of knots : Effects of Knots and Sever Bends on Rope Strength. Has a rule of thumb except 50%.
 - Fatigue : is the weakening of a material caused by repeatedly applied loads.
 - Inspection : careful examination
 - Line : Life line, safe line, Line in pulley
 - Marlin Spike : a pointed metal tool used by sailors to separate strands of rope or wire, especially in splicing.
-
-

Lexicon

- Newton Law, #3 : For every action there is an equal and opposite re-action.
 - Newton : the standard unit of force in the International System of Units (SI), equal to the force that produces an acceleration of one meter per second per second on a mass of one kilogram.
 - Kn : $1 \text{ N} = 1 \text{ kg} \cdot \text{m}/\text{s}^2$ or 1 kN, is 102.0 kgf, or about 100 kg of load. (rule of thumb 10 for 1 in kg on earth)
 - OSHA and ANSI : The Occupational Safety and Health Administration. American National Standards Institute
 - Quick Link, metal connective piece.
 - Rope : a length of strong cord made by twisting together strands of natural fibers such as hemp or artificial fibers such as polypropylene.
-
-

Lexicon

- Shackle : a metal link, different of quick link.
 - Safety factor : is a term describing the load carrying capacity of a system beyond the expected or actual loads.
 - Sling : a flexible strap or belt used in the form of a loop to support or raise a weight.
 - Spanset, Construction grade sling
 - Shock Load : A sudden or unexpected load that is imposed upon a system.
 - Torsion : the action of twisting or the state of being twisted, especially of one end of an object relative to the other.
 - Type of ropes. See Annex
 - Truss : Truss structure is designed to support huge loads in comparison to its weight
-
-

Lexicon

- SWL : Safe Working Load under a safety design
 - ALL : Allowed load Limits
 - AWL : Allowed working load
 - RWL : Recommended Weight Limits
 - WLL : Working Load Limits
-
- MBS : Minimum Breaking Strength, The average static force required to break a piece of gear if you pull on it.
-
-

Knots Strength or Efficiency of knots.

Knot Strength	
Type of Knot, Bend or Hitch	Percentage of Retained Strength
No Knot	100%
Double Fisherman's	65-70%
Bowline	70-75%
Water Knot	60-70%
Figure 8	75-80%
Clove Hitch	60-65%
Fisherman's	60-65%
Overhand	60-65%
Anchor Bend	
Over 5/8" Dia. Ring	55-65%
Over 4" Dia. Post	80-90%
Two Half Hitches	
Over 5/8" Dia. Ring	60-70% *
Over 4" Dia. Post	65-75% *
Square Knot	43-57% *
Sheet Bend	48-58% *
Carrick Bend	55-60%

Force, Vector, Angle

Newton laws

•

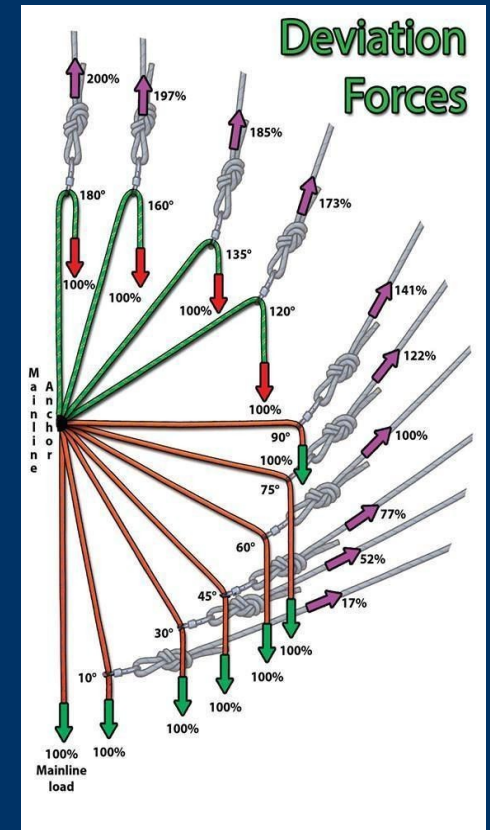
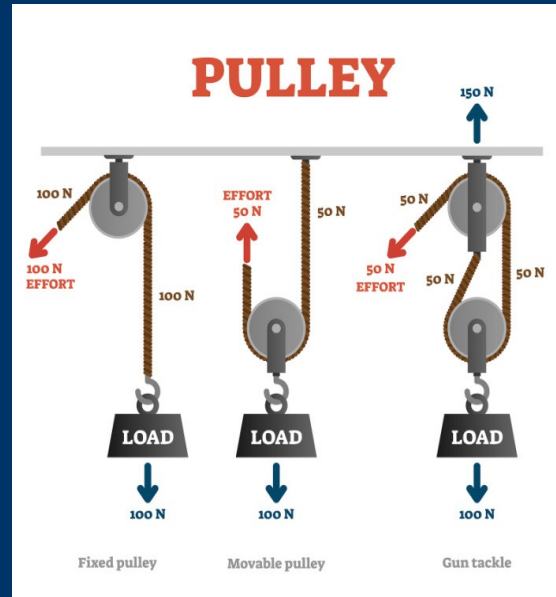
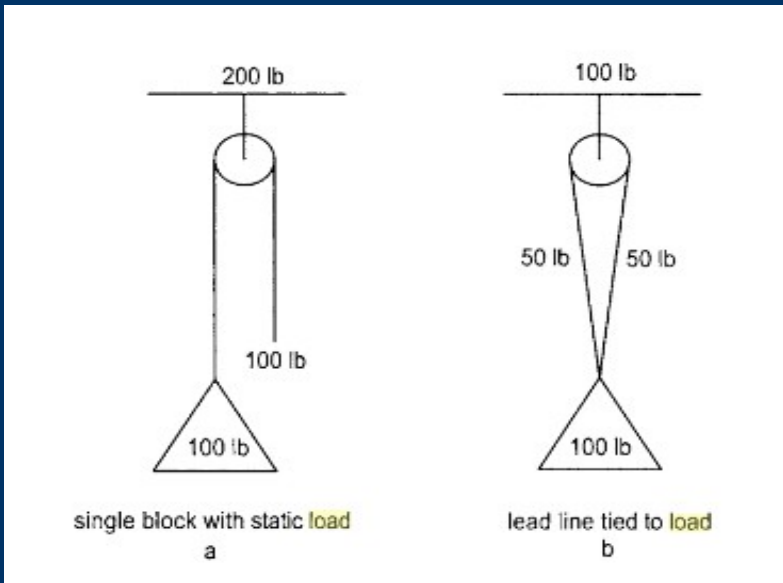

Force , Vector , Angle

Sling Angle Factor

The Sling Angle Factor is a multiplier used to determine the required sling size when angle formed between sling and load is less than 90°.

Need to estimate angle to nearest 5°

Avoid rigging loads where angle is less than 45°

Sling angle	Load angle factor
90°	1.000
85°	1.004
80°	1.015
75°	1.035
70°	1.064
65°	1.103
60°	1.155
55°	1.221
50°	1.305
45°	1.414
40°	1.555
35°	1.742
30°	2.000
25°	2.366
20°	2.924
15°	3.864
10°	5.759
5°	11.47

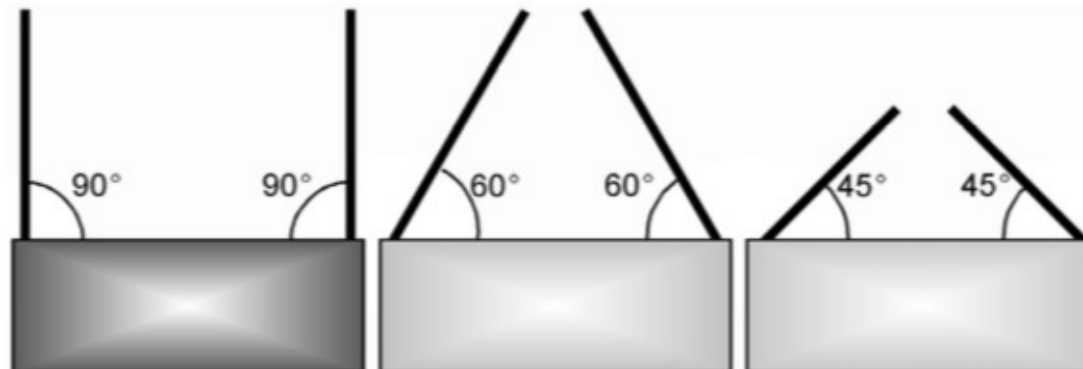

Force , Vector , Angle

Sling Angle Factor

The Sling Angle Factor is a multiplier used to determine the required sling size when angle formed between sling and load is less than 90°.

Need to estimate angle to nearest 5°

Avoid rigging loads where angle is less than 45°

Sling angle	Load angle factor
90°	1.000
85°	1.004
80°	1.015
75°	1.035
70°	1.064
65°	1.103
60°	1.155
55°	1.221
50°	1.305
45°	1.414
40°	1.555
35°	1.742
30°	2.000
25°	2.366
20°	2.924
15°	3.864
10°	5.759
5°	11.47

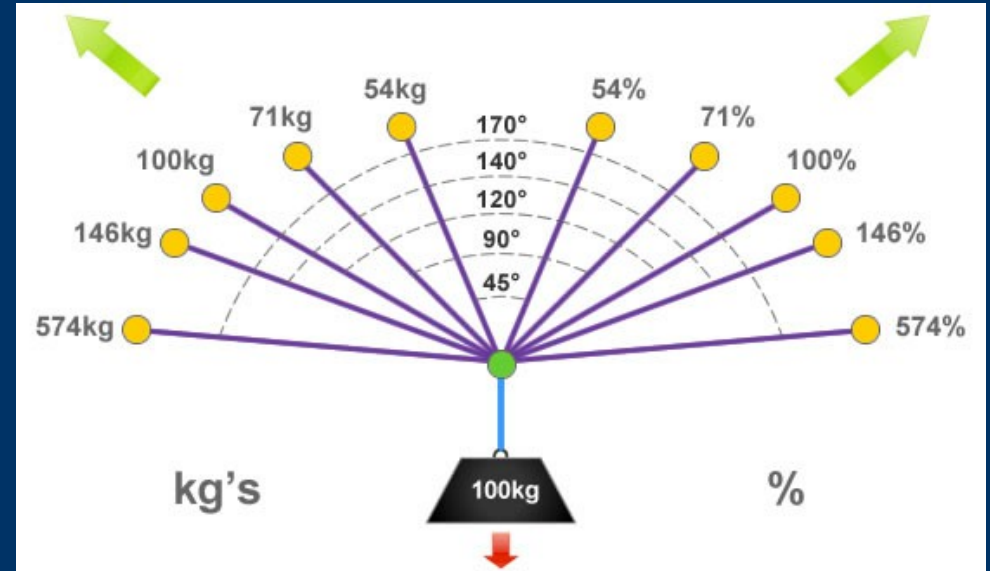
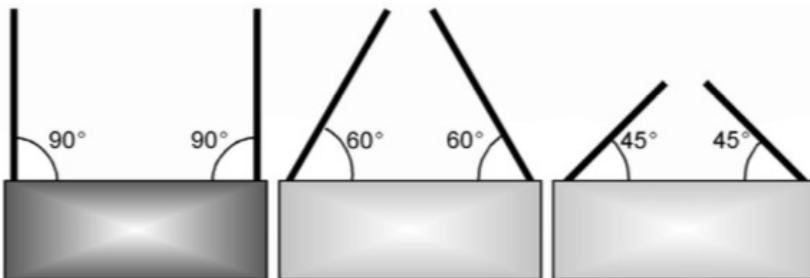

Design and Estimation

Estimation of Rope strenght

- Perfect condition, Brand New, or manufactur provided.

$B_s = C^2 \times R_F$, Rope factor MBS at 1 inch

- B_s : Breaking Strenght in Lbs
- C : Circonference in Inch
- 900: manilla factor
- -Manilla 900
- -Nylon 2400
- -Polyprolilne 1300
- -Sysal 750
- -Hemps / jute 800
- -Cotton 600
- -Hempex 1800

Rope	6 mm	8mm
Manilla	495lbs	881lbs
Nylon	1321lbs	2349lbs
Poly	715lbs	1272lbs
Hemp	440lbs	783lbs
Hempex	991lbs	1762lbs

Newton Practice

22kn = how many kg

5000lbs = how many KN

2500kg = how many KN

200lbs = how many Kn

How many people of 200lbs to break a 22Kn

Newton Practice

$$22\text{kn} = 4945,79\text{lbs} = 2243.37 \text{ kg}$$

$$5000\text{lbs} = 22.2\text{kn}$$

$$2500\text{kg} = 24.5 \text{ kn} = 24\ 500 \text{ N}$$

$$1\text{kg} = 10 \text{ N}$$

$$200\text{lbs} = 200 / 2.2 = 91 \text{ kg} \times 10 = 910 \text{ N} \pm 1\text{Kn}$$

22

Design and Estimation

Break 5 min

WOULD YOU HANG YOUR CAR ON THAT?



According to aerial industry rig point standards, each rig point should be able to hold 2,000 - 5,000 lbs.

The average car weighs between 2,000 - 5,000 lbs.

Professional aerialists seek the advice of professional riggers when hanging their equipment. It's too important to make assumptions.

Be safe and happy flying!

Get your own copy of this flyer at www.circusbuilding.com.

Design and Estimation

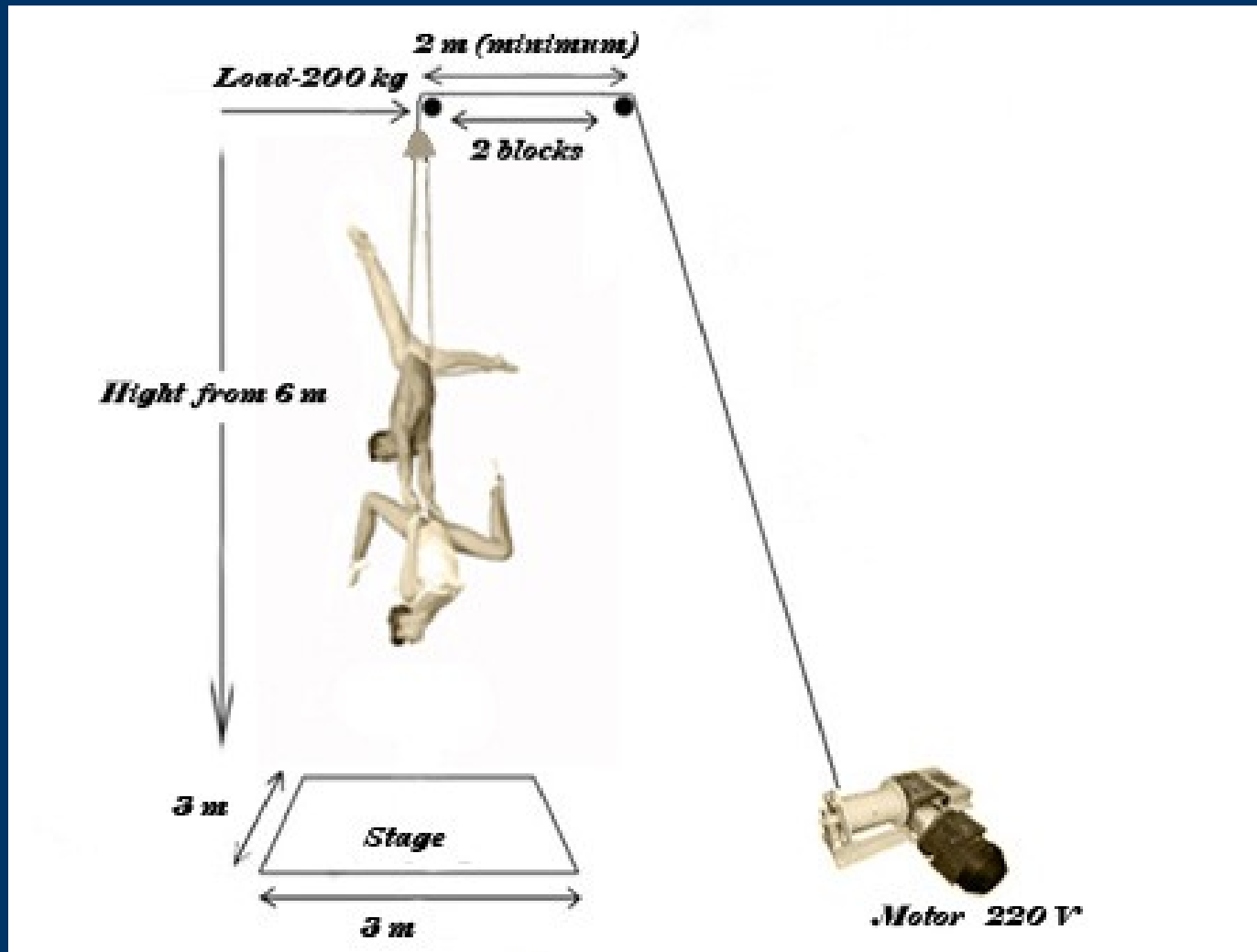

Design and Estimation

- Pulley Direct 100lbs
- Pulley in line 100lbs
- Pulley direct, weight

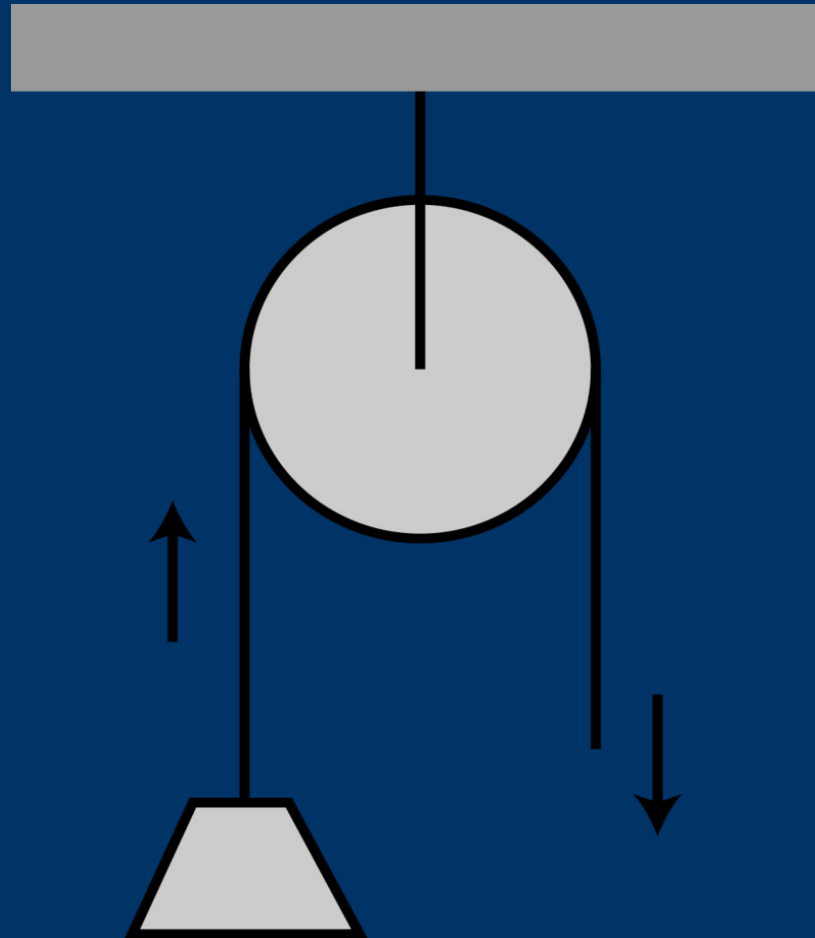

▣ *Frame, Anchor*

- A frame
 - Tripode, Quadripode , tetruss , S3 ,
 - Truss , rigg and suspended
 - H wood frame
 - Beam, wood, H , I
 - Aerial portable frame
-
-

▣ *Frame, Anchor*

- A frame



▣ *Frame, Anchor*

- Tripod



▣ *Frame, Anchor*

- Truss

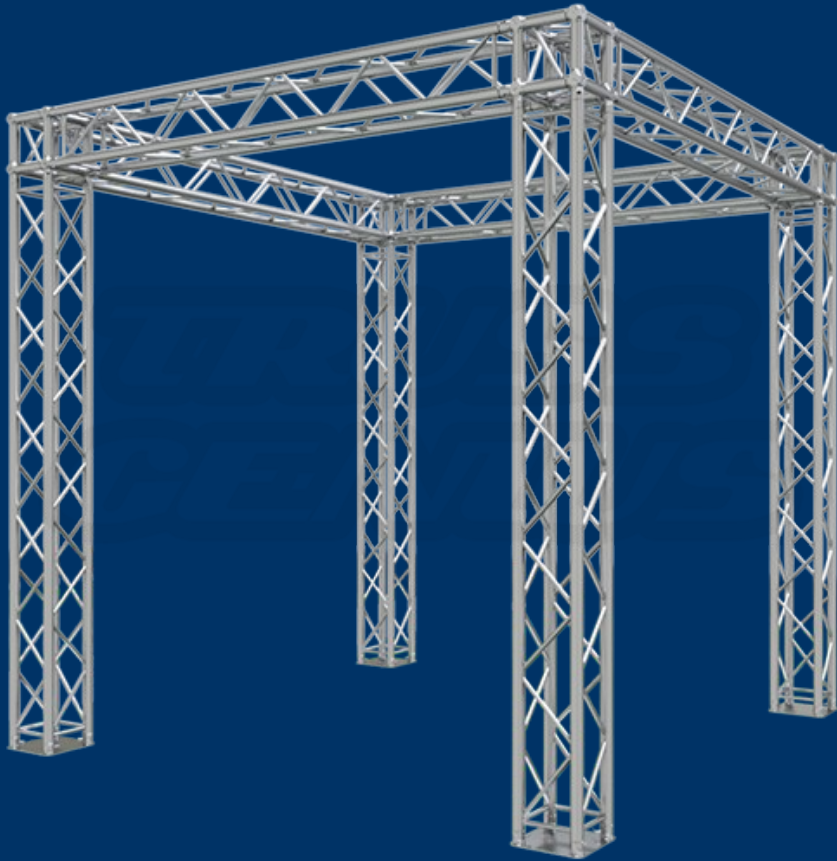

▣ *Frame, Anchor*

- H frame



Bondage Frame

Our furniture is like nothing you've ever seen. It's human-driven design means you decide when to take action, as opposed to simple repeating animations. It's compatible with ToKon and Xcite! gear as well as LockGuard and Restrained Love.

The cross features six positions for the submissive and a TON of pain and pleasure interactions such as anal sex, vaginal sex, fisting, whipping, flogging, spanking, caning and more. This item includes several HUDs that allow you to change the look.

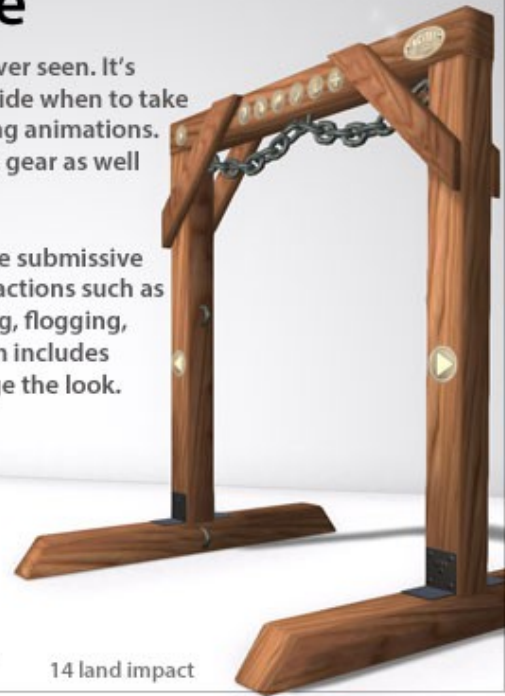

Unlimited copies • No transfer • No modify

14 land impact

▣ *Frame, Anchor*

- Beam

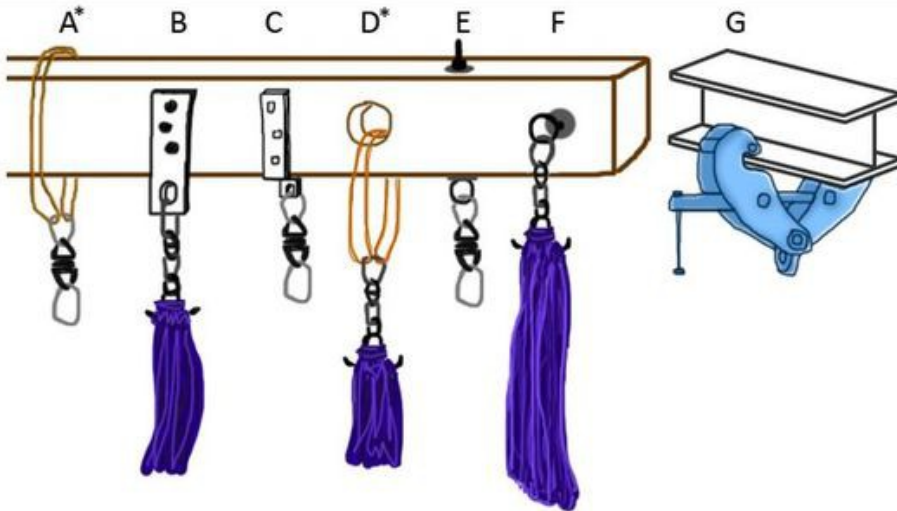

- Wrap sling loop tightly around beam/joist/support point
- Attach rigging plate to beam with secure bolts (minimum thickness .5inch)
- Attach rigging plate to beam with secure bolts (minimum thickness .5inch)
- Drill 1" hole through middle of beam, thread sling loop through
- Eyebolt drilled vertically - washer, lock washer, and nut on other side.
- Eyebolt drilled horizontally - washer, lock washer and nut on other side
- Steel I-Beams can be easily rigged with a simple 1ton clamp.

* Illustration does not properly depict the tightness suggested for the sling loop.
The tighter the sling loop the more secure the rigging point.
You want your hardware/carabiner as close to the beam as possible.



▣ *Frame, Anchor*

- Wood Anchor



▣ *Frame, Anchor*

- Cement

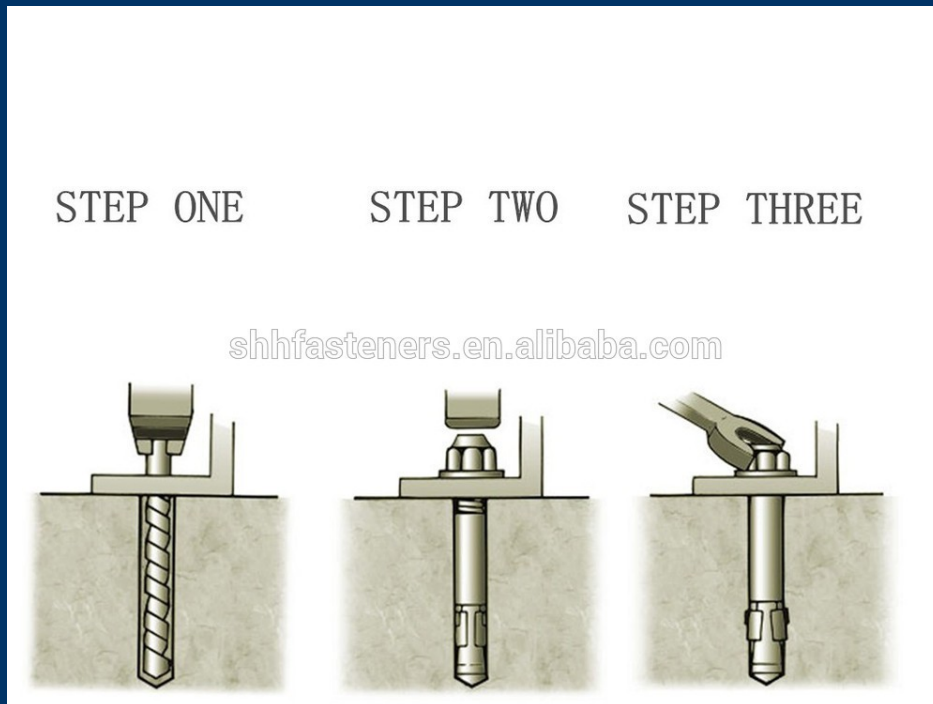









Frame Anchor



Frame Anchor

- Sling , cable, ropes, strap, spenset.

Lifting Mode								
ANGLE	VERTICAL	CHOKE	BASKET PARALLEL	BASKET 30°	BASKET 60°	BASKET 90°	2 LBG SLING 0° to 90°	4 LBG SLING 0° to 90°
W.L.L. KG	S.W.L KG	S.W.L KG	S.W.L KG	S.W.L KG	S.W.L KG	S.W.L KG	S.W.L KG	S.W.L KG
500	500	400	1000	950	850	700	850	1000
1000	1000	800	2000	1900	1700	1400	1700	2000
2000	2000	1600	4000	3800	3400	2800	3400	4000
3000	3000	2400	6000	5700	5100	4200	5100	6000
4000	4000	3200	8000	7600	6800	5600	6800	8000
5000	5000	4000	10,000	9500	8500	7000	8500	10,000
6000	6000	4800	12,000	11,400	10,200	8400	10,200	12,000
8000	8000	6400	16,000	15,200	13,600	11,200	13,600	16,000
10,000	10,000	8000	20,000	19,000	17,000	14,000	17,000	20,000
12,000	12,000	9600	24,000	22,800	20,400	16,800	20,400	24,000

Multi point Anchor

- 1 point, 360 swing mouvement,
- 2 point, 2 direction mouvement, swing
- 3 point, lock in place.

Ropes & Knots

- Elongation, elongation before snap.
 - Flexibility, Diameter of the rope vs diameter of the bend. $D=3xd$
 - Durability, Decomposition, UV degradation. (5 years)
 - Low Burning, Self melting.
 - Strength
 - Cost
 - Size
 - Weight
 - Value
 - Twist (s/z), braid
 - Preparation, Cleaning and inspection.
-
-

Ropes & Knots

Knot Strength	
Type of Knot, Bend or Hitch	Percentage of Retained Strength
No Knot	100%
Double Fisherman's	65-70%
Bowline	70-75%
Water Knot	60-70%
Figure 8	75-80%
Clove Hitch	60-65%
Fisherman's	60-65%
Overhand	60-65%
Anchor Bend	
Over 5/8" Dia. Ring	55-65%
Over 4" Dia. Post	80-90%
Two Half Hitches	
Over 5/8" Dia. Ring	60-70% *
Over 4" Dia. Post	65-75% *
Square Knot	43-57% *
Sheet Bend	48-58% *
Carrick Bend	55-60%

Ropes & Knots

- Figure 8 loop
- Clove Hitch
- Bowline
- Water knots
- 8 lock
- Prusik knots
- Test swing



Pulley and winch

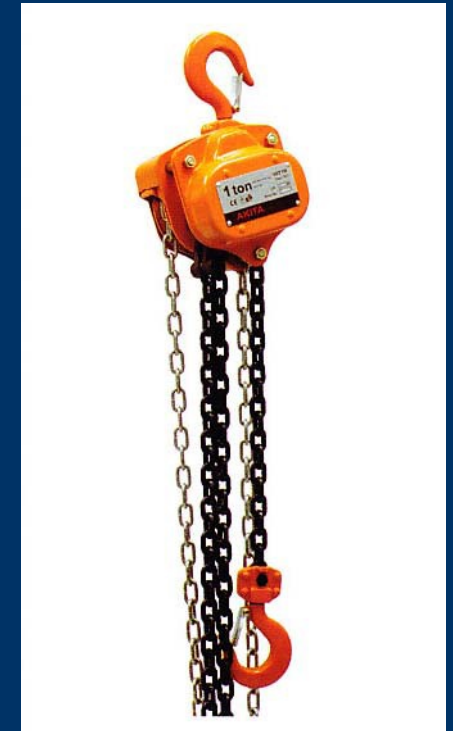
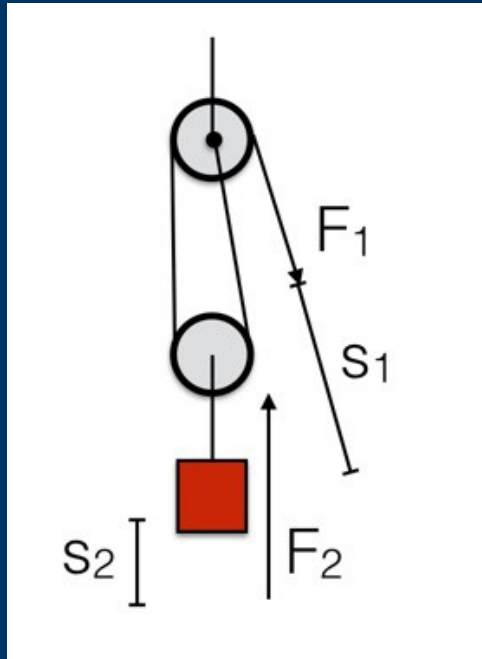

Hardware

- Shackle
 - Quick Link
 - Carabiner
 - Sling, daisy chain, chain, cables
 - Swivel
 - Pulley
 - Ascender/desender
 - Marlin Spike / safety Shear
 - Ring , Plate
 - Ascender climbing
-
-

Hardware

Shackle Pre-Use Inspection Checklist

Inspect shackles daily before use and frequently during use.

- Each shackle body shall have forged, cast, or die stamped markings by the manufacturer showing: name or trademark of the manufacturer, rated load/capacity (WLL or SWL), and size. This information shall not be missing and must be legible.



Remove from service when any of the following conditions exist:

- Indications of heat damage including weld spatter or arc strikes
- Excessive pitting or corrosion
- 10% reduction of the original or catalog dimension at any point around the body or pin
- Body spread including: bent, twisted, distorted, stretched, elongated, cracked, or broken load-bearing components
- Excessive nicks or gouges
- Incomplete pin engagement, shoulder of pin is not flush with shackle body
- Excessive thread damage
- Evidence of unauthorized welding

Never Replace a Shackle Pin with a Bolt



The Load will Bend the Bolt

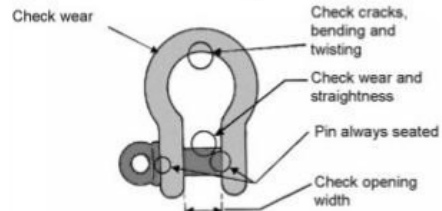

Incorrect Applications

Side Loading Reduction Factors Screw Pin and Bolt Type Shackles

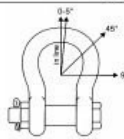

Angle of Side Load from Vertical In-Line of Shackle	Percent Rated Load Reduction
0° - 5°	0%
5° - 45°	30%
46° - 90°	50%
Over 90°	Avoid

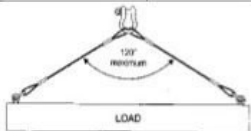

The rated capacity of shackles only applies when they are symmetrically loaded and the included angle between two sling legs is a maximum of 120°. Shackle capacity must be reduced when the angle is greater than 120°.

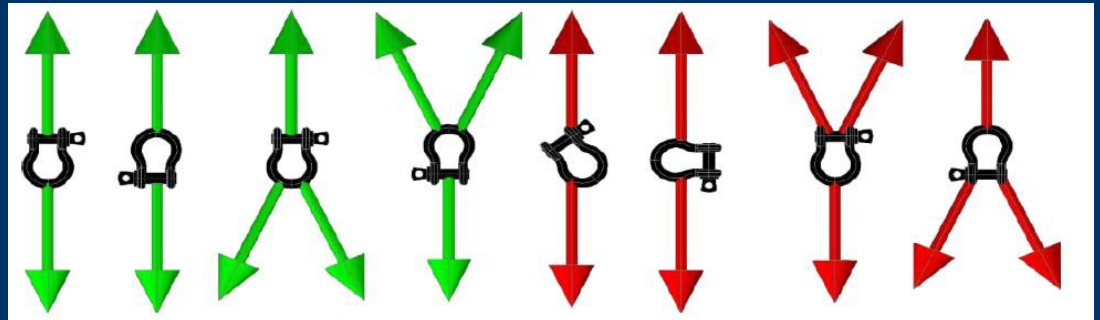

Hardware



Bad Hardware

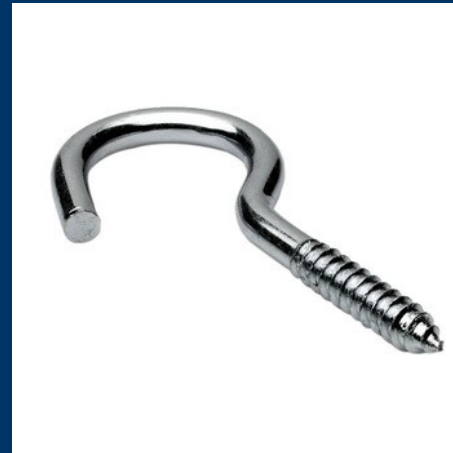
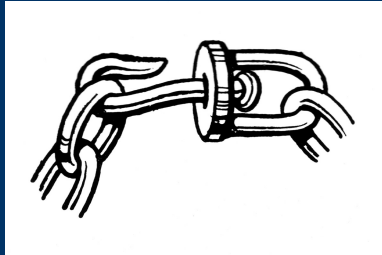

Laws & certification & insurance

- OSHA and ANSI compliance. (5000lbs , 10x)
 - Fire Marshal (Metal over Metal)
 - ECTP, workshop
 - Circus association insurance
-
-

Less know danger

- Orthostatic Syndrome
- HHS, Harness Hangman Syndrome
- American triangle of Death.

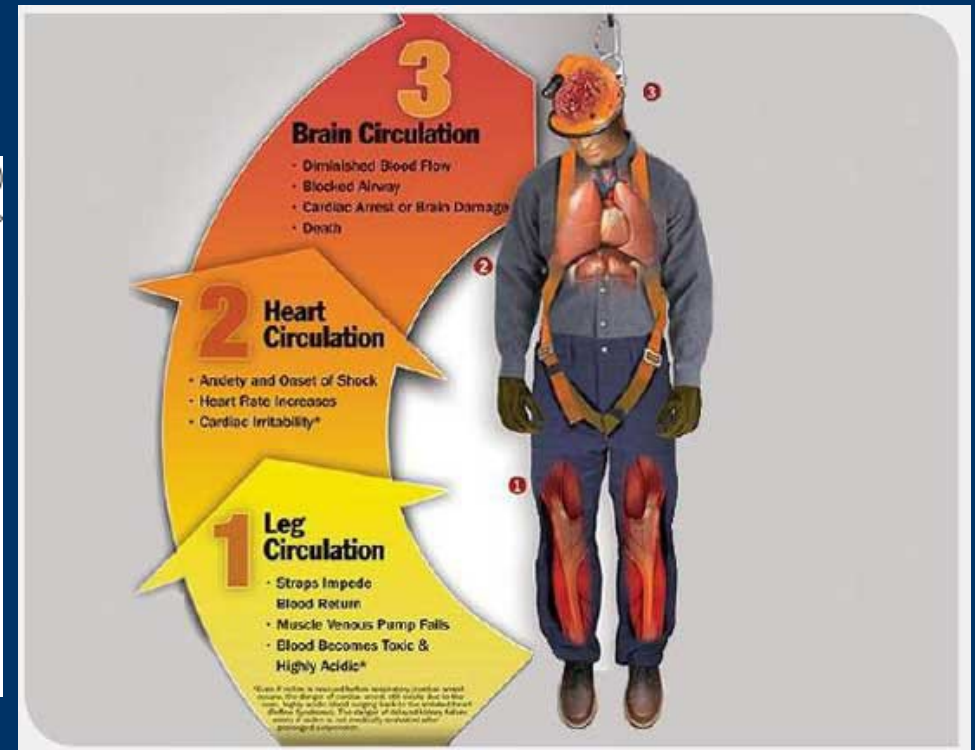
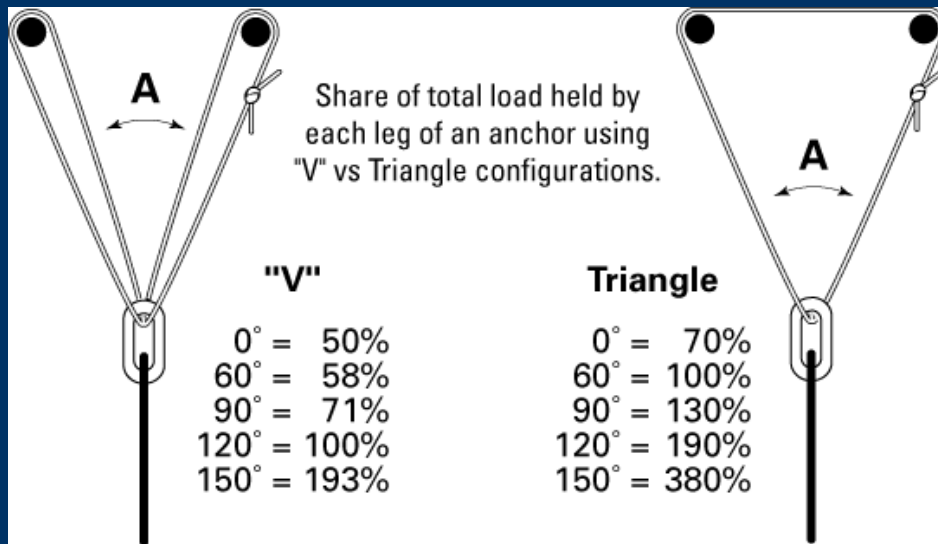

Annex 1, ropes

Natural

- Cotton
- Jute
- Hemp
- Silk

Mixte, Compound

Synthetic

- Nylon
 - Poly,MFP
 - Aramid
 - Dyneema
- 

Math

- Working Load Limit
- The maximum force that you should load a component is the working load limit (WLL). The WLL incorporates a safety factor (SF). The SF provides additional protection above the manufacturer's design factor (DF). The design factor is the safety factor to which the manufacturer builds. The SF and DF do not provide added capacity. You must never exceed the WLL.
- Let's calculate the WLL of a chain or gin wheel rated at 1000 pounds with a manufacturer's DF of 3.
- Note: Section 172 (1) (d) of the Construction Regulation requires a SF of 5.
- This requirement is greater than our DF, so the capacity must be reduced accordingly.
- $WLL = 1000 \text{ pounds (rated capacity)} \times 3 \text{ (DF)} / 5 \text{ (SF)}$
- $WLL = 600 \text{ pounds}$

Accident

- Lost of conciencia
- Rope Breaking, Death drop.
- Ring, quick link, anchor breaking
- Accidental release, Puley and other.
- Opening Shackle
- Knots undone
- Untwisting anchor
- Tension breaking
-
-
-

